

SP3T-6T 26.5GHz

Load
Normally open/Latching

◆ RF Characteristics

Frequency (GHz)	Ins.loss (dB)	Isolation (dB)	VSWR	RF Power CW (W)
DC-6	0.3	70	1.3	80
6-12	0.4	60	1.4	60
12-18	0.5	50	1.5	50
18-26.5	0.6	50	1.6	15

◆ Operating Voltage/Coil Current

Operating Voltage(V)	12	24	28	
Coil Current (mA)	Normally open	300	200	180
	Latching	320	200	180
	Latching(RESET)	1920	1200	1080

* It can be selected according to user requirements

TTL	TTL Low(V)	TTL High	
	0-0.3	3~5V	1.4mA

Indicators	Withstand Voltage V (max)	Current capacity mA (max)	Resistance Ω (max)
	50	100	15

* Connect VDC & GND before the function operates

◆ Outline Drawing

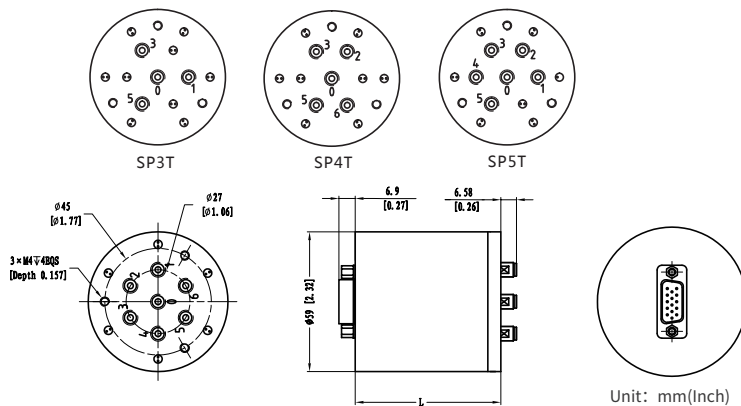

L = 61.5(Non TTL/TTL/Indicators)

◆ Backplane

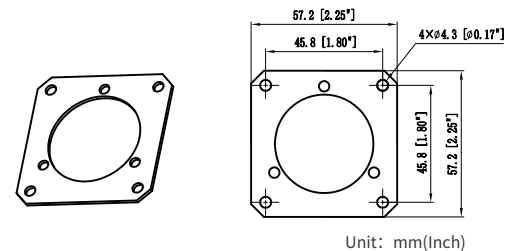

◆ Product Functions

- DC to 26.5GHz
- Low loss, Low VSWR, High Isolation
- SMA Connector
- Selectable TTL driver control

◆ Specifications

Switching Sequence: Break before Make

Switching Time: 15ms max

Storage temperature: -55°C~85°C

Operating temperature: -25°C~65°C(Standard)
-45°C~85°C(Extended1)
-55°C~85°C(Extended2)

Mechanical Life Cycles: 2 million cycles

RF Connectors: SMA Female

Impedance: 50Ω

Mechanical Shock,Non-Operating: 50G、1/2 Sine、11 ms

Vibration Operating: 20-2000 Hz、10G RMS

Actuator Terminals: D-SUB 15/26Pin Male

Weight: 260g

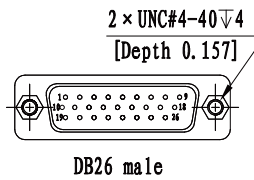
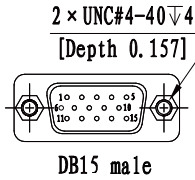

◆ Truth Table

* For Latching mode, there is no indication function, and the control interface is DB15 Male.

Latching Non TTL					
Actuator Terminals		RF Connector			
D-SUB 15/26Pin Male					
Pin No.	Define	SP3T	SP4T	SP5T	SP6T
1	V1	RF 1-0	-	RF 1-0	RF 1-0
2	V2	-	RF 2-0	RF 2-0	RF 2-0
3	V3	RF 3-0	RF 3-0	RF 3-0	RF 3-0
4	V4	-	-	RF 4-0	RF 4-0
5	V5	RF 5-0	RF 5-0	RF 5-0	RF 5-0
6	V6	-	RF 6-0	-	RF 6-0
7	V (RESET)	-	-	-	-
8	GND	-	-	-	-
9	Ind.1	RF 1-0	-	RF 1-0	RF 1-0
10	Ind.2	-	RF 2-0	RF 2-0	RF 2-0
11	Ind.3	RF 3-0	RF 3-0	RF 3-0	RF 3-0
12	Ind.4	-	-	RF 4-0	RF 4-0
13	Ind.5	RF 5-0	RF 5-0	RF 5-0	RF 5-0
14	Ind.6	-	RF 6-0	-	RF 6-0
15	Ind.com	-	-	-	-
16	VDC	-	-	-	-
17~26		N/A			

Note: The switch should be powered on pin7 before RESET!

Latching TTL					
Actuator Terminals		RF Connector			
D-SUB 15/26Pin Male					
Pin No.	Define	SP3T	SP4T	SP5T	SP6T
1	TTL	RF 1-0	-	RF 1-0	RF 1-0
2	TTL	-	RF 2-0	RF 2-0	RF 2-0
3	TTL	RF 3-0	RF 3-0	RF 3-0	RF 3-0
4	TTL	-	-	RF 4-0	RF 4-0
5	TTL	RF 5-0	RF 5-0	RF 5-0	RF 5-0
6	TTL	-	RF 6-0	-	RF 6-0
7	TTL (RESET)	-	-	-	-
8	VDC	-	-	-	-
9	GND	-	-	-	-
10	Ind.1	RF 1-0	-	RF 1-0	RF 1-0
11	Ind.2	-	RF 2-0	RF 2-0	RF 2-0
12	Ind.3	RF 3-0	RF 3-0	RF 3-0	RF 3-0
13	Ind.4	-	-	RF 4-0	RF 4-0
14	Ind.5	RF 5-0	RF 5-0	RF 5-0	RF 5-0
15	Ind.6	-	RF 6-0	-	RF 6-0
16	Ind.com	-	-	-	-
17~26		N/A			

Note: The switch should be powered on pin7 before RESET!

Normally open Non TTL					
Actuator Terminals		RF Connector			
D-SUB 15Pin Male					
Pin No.	Define	SP3T	SP4T	SP5T	SP6T
1	V1	RF 1-0	-	RF 1-0	RF 1-0
2	V2	-	RF 2-0	RF 2-0	RF 2-0
3	V3	RF 3-0	RF 3-0	RF 3-0	RF 3-0
4	V4	-	-	RF 4-0	RF 4-0
5	V5	RF 5-0	RF 5-0	RF 5-0	RF 5-0
6	V6	-	RF 6-0	-	RF 6-0
7	GND	-	-	-	-
8	Ind.1	RF 1-0	-	RF 1-0	RF 1-0
9	Ind.2	-	RF 2-0	RF 2-0	RF 2-0
10	Ind.3	RF 3-0	RF 3-0	RF 3-0	RF 3-0
11	Ind.4	-	-	RF 4-0	RF 4-0
12	Ind.5	RF 5-0	RF 5-0	RF 5-0	RF 5-0
13	Ind.6	-	RF 6-0	-	RF 6-0
14	Ind.com	-	-	-	-
15	VDC	-	-	-	-

Normally open TTL					
Actuator Terminals		RF Connector			
D-SUB 15Pin Male					
Pin No.	Define	SP3T	SP4T	SP5T	SP6T
1	TTL	RF 1-0	-	RF 1-0	RF 1-0
2	TTL	-	RF 2-0	RF 2-0	RF 2-0
3	TTL	RF 3-0	RF 3-0	RF 3-0	RF 3-0
4	TTL	-	-	RF 4-0	RF 4-0
5	TTL	RF 5-0	RF 5-0	RF 5-0	RF 5-0
6	TTL	-	RF 6-0	-	RF 6-0
7	VDC	-	-	-	-
8	GND	-	-	-	-
9	Ind.1	RF 1-0	-	RF 1-0	RF 1-0
10	Ind.2	-	RF 2-0	RF 2-0	RF 2-0
11	Ind.3	RF 3-0	RF 3-0	RF 3-0	RF 3-0
12	Ind.4	-	-	RF 4-0	RF 4-0
13	Ind.5	RF 5-0	RF 5-0	RF 5-0	RF 5-0
14	Ind.6	-	RF 6-0	-	RF 6-0
15	Ind.com	-	-	-	-

◆ Product Selection

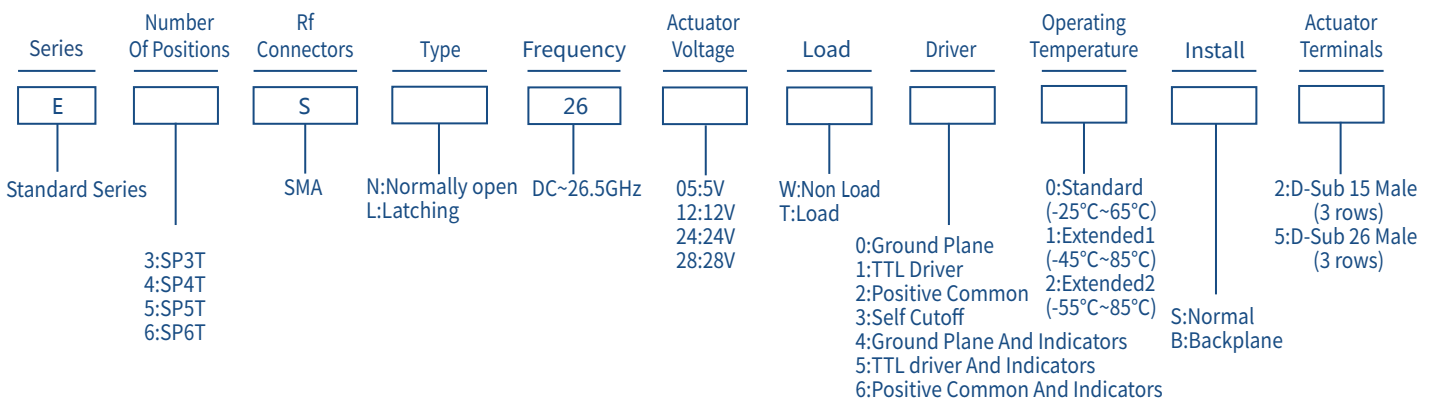

★ EXP: E3SN2605W00S2: Standard Series, SP3T, SMA, Normally open, DC~26.5GHz, 5V, Non Load, Ground Plane, Standard, Normal, D-Sub 15 Male.