

# Smart



## ◆ Specifications

- Miniaturized
- Low High Cost Performance
- Touchable Screen Interface Design
- Provide Remote Control Interface And Instructions
- Simple Operation

# SP8T 18/26.5/40GHz USB

## ◆ RF Characteristics

Frequency (GHz)	Ins.loss (dB)	Isolation (dB)	VSWR	RF Power CW (W)
DC-6	0.3	70	1.3	40
6-12	0.4	60	1.4	30
12-18	0.5	55	1.5	25
18-26.5	0.7	50	1.7	12
26.5-32	0.8	50	1.8	8
32-40	0.9	50	1.9	5



## ◆ Product Functions

- DC to 40GHz
- Low loss, Low VSWR, High Isolation
- SMA/2.92 Connector
- Channel Indicator Light Function

## ◆ Operating Voltage/Coil Current

Operating Voltage(V)		12
Coil Current(mA)	Normally open	300

## ◆ Outline Drawing

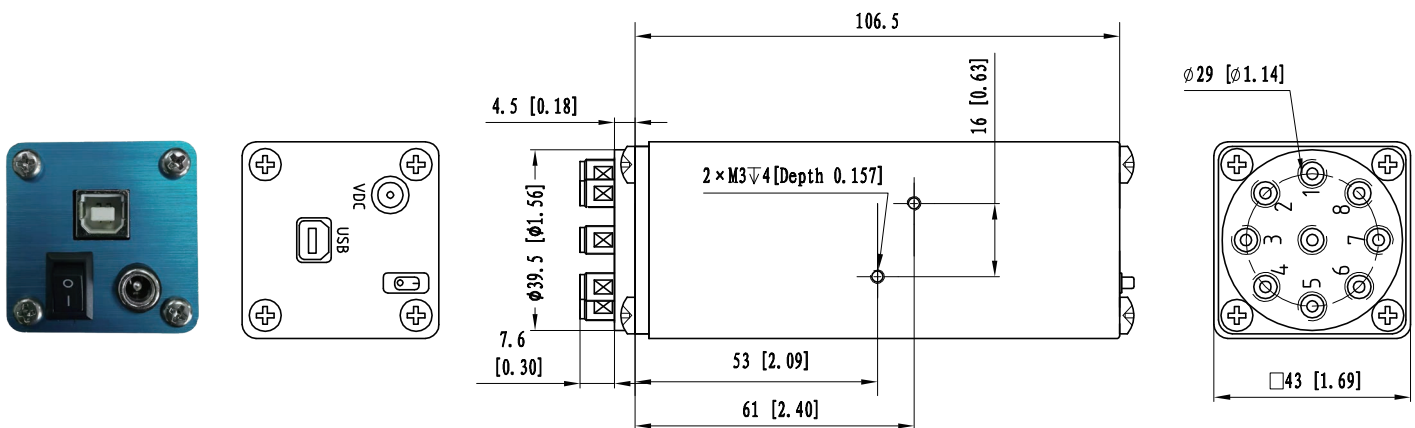

## ◆ Specifications

Switching Sequence: Break before Make	Mechanical Life Cycles: 2 million cycles	Mechanical Shock, Non-Operating: 50G、1/2 Sine、11 ms
Switching Time: 15ms max	RF Connectors: SMA/2.92	Vibration Operating: 20-2000 Hz、10G RMS
Storage temperature: -55°C~85°C	Impedance: 50Ω	Actuator Terminals: USB
Operating temperature: -25°C~65°C(Standard)		Weight: 300g
-45°C~85°C(Extended1)		
-55°C~85°C(Extended2)		