

SP9T-10T 26.5GHz

Load Normally open/Latching

◆ RF Characteristics

Frequency (GHz)	Ins.loss (dB)	Isolation (dB)	VSWR	RF Power CW (W)
DC-6	0.3	70	1.3	80
6-12	0.4	60	1.4	60
12-18	0.5	50	1.5	50
18-26.5	0.7	50	1.7	15

◆ Operating Voltage/Coil Current

Operating Voltage(V)		12	24	28
Coil Current (mA)	Normally open	300	200	180
	Latching	320	200	180
	Latching(RESET)	3200	2000	1800

* It can be selected according to user requirements

TTL	TTL Low(V)	TTL High	
	0-0.3	3~5V	1.4mA

Indicators	Withstand Voltage V (max)	Current capacity mA(max)	Resistance Ω (max)
	50	100	15

* Connect VDC & GND before the function operates

◆ Outline Drawing

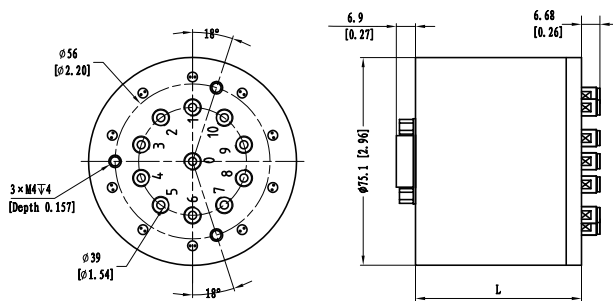

L = 61.5(Non TTL/TTL/Indicators)



◆ Product Functions

- DC to 26.5GHz
- Low loss, Low VSWR, High Isolation
- SMA Connector
- Selectable TTL driver control

◆ Backplane

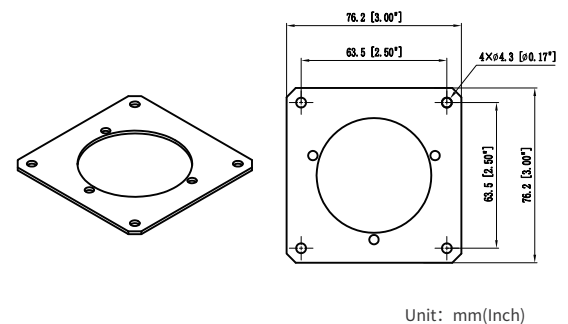

◆ Specifications

Switching Sequence: Break before Make

Switching Time: 15ms max

Storage temperature: -55°C~85°C

Operating temperature:-25°C~65°C(Standard)

-45°C~85°C(Extended1)

-55°C~85°C(Extended2)

Mechanical Life Cycles: 2 million cycles

RF Connectors: SMA Female

Impedance: 50Ω

Mechanical Shock,Non-Operating: 50G、1/2 Sine、11 ms

Vibration Operating: 20-2000 Hz、10G RMS

Actuator Terminals: D-SUB 15/26Pin Male

Weight: 405g

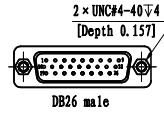
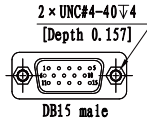

◆ Truth Table

* No indication function, control interface DB15 Male.

Normally open Non TTL			
Actuator Terminals		RF Connector	
D-SUB 15/26Pin Male			
Pin No.	Define	SP9T	SP10T
1	V1	RF 1-0	RF 1-0
2	V2	RF 2-0	RF 2-0
3	V3	RF 3-0	RF 3-0
4	V4	RF 4-0	RF 4-0
5	V5	RF 5-0	RF 5-0
6	V6	RF 6-0	RF 6-0
7	V7	RF 7-0	RF 7-0
8	V8	RF 8-0	RF 8-0
9	V9	RF 9-0	RF 9-0
10	V10	-	RF 10-0
11	GND	-	-
12	Ind.1	RF 1-0	RF 1-0
13	Ind.2	RF 2-0	RF 2-0
14	Ind.3	RF 3-0	RF 3-0
15	Ind.4	RF 4-0	RF 4-0
16	Ind.5	RF 5-0	RF 5-0
17	Ind.6	RF 6-0	RF 6-0
18	Ind.7	RF 7-0	RF 7-0
19	Ind.8	RF 8-0	RF 8-0
20	Ind.9	RF 9-0	RF 9-0
21	Ind.10	-	RF 10-0
22	Ind.com	-	-
23	VDC	-	-
24~26	N/A	-	-

Normally open TTL			
Actuator Terminals		RF Connector	
D-SUB 15/26Pin Male			
Pin No.	Define	SP9T	SP10T
1	TTL	RF 1-0	RF 1-0
2	TTL	RF 2-0	RF 2-0
3	TTL	RF 3-0	RF 3-0
4	TTL	RF 4-0	RF 4-0
5	TTL	RF 5-0	RF 5-0
6	TTL	RF 6-0	RF 6-0
7	TTL	RF 7-0	RF 7-0
8	TTL	RF 8-0	RF 8-0
9	TTL	RF 9-0	RF 9-0
10	TTL	-	RF 10-0
11	VDC	-	-
12	GND	-	-
13	Ind.1	RF 1-0	RF 1-0
14	Ind.2	RF 2-0	RF 2-0
15	Ind.3	RF 3-0	RF 3-0
16	Ind.4	RF 4-0	RF 4-0
17	Ind.5	RF 5-0	RF 5-0
18	Ind.6	RF 6-0	RF 6-0
19	Ind.7	RF 7-0	RF 7-0
20	Ind.8	RF 8-0	RF 8-0
21	Ind.9	RF 9-0	RF 9-0
22	Ind.10	-	RF 10-0
23	Ind.com	-	-
24~26	N/A	-	-

Latching Non TTL			
Actuator Terminals		RF Connector	
D-SUB 15/26Pin Male			
Pin No.	Define	SP9T	SP10T
1	V1	RF 1-0	RF 1-0
2	V2	RF 2-0	RF 2-0
3	V3	RF 3-0	RF 3-0
4	V4	RF 4-0	RF 4-0
5	V5	RF 5-0	RF 5-0
6	V6	RF 6-0	RF 6-0
7	V7	RF 7-0	RF 7-0
8	V8	RF 8-0	RF 8-0
9	V9	RF 9-0	RF 9-0
10	V10	-	RF 10-0
11	V(RESET)	-	-
12	GND	-	-
13	Ind.1	RF 1-0	RF 1-0
14	Ind.2	RF 2-0	RF 2-0
15	Ind.3	RF 3-0	RF 3-0
16	Ind.4	RF 4-0	RF 4-0
17	Ind.5	RF 5-0	RF 5-0
18	Ind.6	RF 6-0	RF 6-0
19	Ind.7	RF 7-0	RF 7-0
20	Ind.8	RF 8-0	RF 8-0
21	Ind.9	RF 9-0	RF 9-0
22	Ind.10	-	RF 10-0
23	Ind.com	-	-
24	VDC	-	-
25~26	N/A	-	-

Latching TTL			
Actuator Terminals		RF Connector	
D-SUB 15/26Pin Male			
Pin No.	Define	SP9T	SP10T
1	TTL	RF 1-0	RF 1-0
2	TTL	RF 2-0	RF 2-0
3	TTL	RF 3-0	RF 3-0
4	TTL	RF 4-0	RF 4-0
5	TTL	RF 5-0	RF 5-0
6	TTL	RF 6-0	RF 6-0
7	TTL	RF 7-0	RF 7-0
8	TTL	RF 8-0	RF 8-0
9	TTL	RF 9-0	RF 9-0
10	TTL	-	RF 10-0
11	TTL(RESET)	-	-
12	VDC	-	-
13	GND	-	-
14	Ind.1	RF 1-0	RF 1-0
15	Ind.2	RF 2-0	RF 2-0
16	Ind.3	RF 3-0	RF 3-0
17	Ind.4	RF 4-0	RF 4-0
18	Ind.5	RF 5-0	RF 5-0
19	Ind.6	RF 6-0	RF 6-0
20	Ind.7	RF 7-0	RF 7-0
21	Ind.8	RF 8-0	RF 8-0
22	Ind.9	RF 9-0	RF 9-0
23	Ind.10	-	RF 10-0
24	Ind.com	-	-
25~26	N/A	-	-

Note: The switch should be powered on pin11 before RESET!

Note: The switch should be powered on pin11 before RESET!

◆ Product Selection

Series	Number Of Positions	Rf Connectors	Type	Frequency	Actuator Voltage	Load	Driver	Operating Temperature	Install	Actuator Terminals
E		S		26						
Standard Series	9:SP9T K:SP10T	SMA	N:Normally Open L:Latching	DC~26.5GHz	05:5V 12:12V 24:24V 28:28V	W:Non Load T:Load	0:Ground Plane 1:TTL Driver 2:Positive Common 3:Self Cutoff 4:Ground Plane And Indicators 5:TTL driver And Indicators 6:Positive Common And Indicators	0:Standard (-25°C~65°C) 1:Extended1 (-45°C~85°C) 2:Extended2 (-55°C~85°C)	S:Normal B:Backplane	2:D-Sub 15 Male (3 rows) 5:D-Sub 26 Male (3 rows)

★ EXP: E9SN2605W00S2: Standard Series, SP9T, SMA, Normally Open, DC-26.5GHz, 5V, Non Load, Ground Plane, Standard, Normal, D-Sub 15 Male.