

SP7T-8T 18GHz

Normally open

◆ RF Characteristics

Frequency (GHz)	Ins.loss (dB)	Isolation (dB)	VSWR	RF Power CW (W)
DC-6	0.3	70	1.3	80
6-12	0.4	60	1.4	60
12-18	0.5	55	1.5	50



◆ Operating Voltage/Coil Current

Operating Voltage(V)	12	24	28	
Coil Current (mA)	Normally open	300	150	140

* It can be selected according to user requirements

TTL	TTL Low(V)	TTL High	
	0-0.3	3~5V	1.4mA

Indicators	Withstand Voltage V (max)	Current capacity mA(max)	Resistance Ω (max)
	50	100	15

* Connect VDC & GND before the function operates

◆ Product Functions

- DC to 18GHz
- Low loss, Low VSWR, High Isolation
- SMA Connector
- Selectable TTL driver control

◆ Outline Drawing

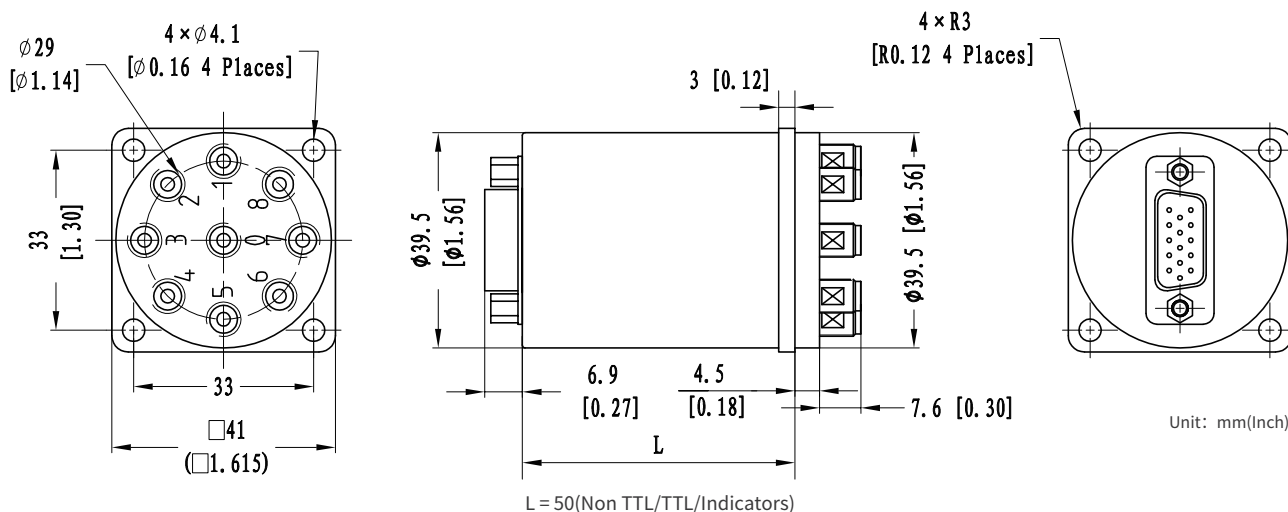

◆ Specifications

Switching Sequence: Break before Make	Mechanical Life Cycles: 2 million cycles	Mechanical Shock,Non-Operating: 50G、1/2 Sine、11 ms
Switching Time: 15ms max	RF Connectors: SMA Female	Vibration Operating: 20-2000 Hz、10G RMS
Storage temperature: -55°C~85°C	Impedance: 50Ω	Actuator Terminals: D-SUB 15/26Pin Male
Operating temperature: -25°C~65°C(Standard)		Weight: 145g
-45°C~85°C(Extended1)		
-55°C~85°C(Extended2)		

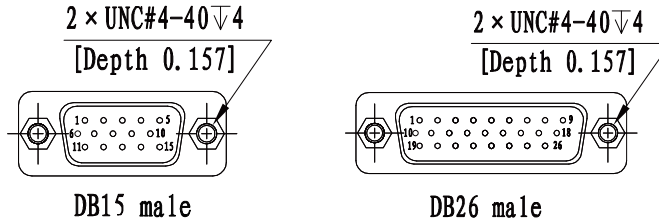

* Note: No indication function, control interface DB15 Male.

◆ Truth Table

Normally open Non TTL			
Actuator Terminals		RF Connector	
D-SUB 15/26Pin Male			
Pin No.	Define	SP7T	SP8T
1	V1	RF 1-0	RF 1-0
2	V2	RF 2-0	RF 2-0
3	V3	RF 3-0	RF 3-0
4	V4	RF 4-0	RF 4-0
5	V5	RF 5-0	RF 5-0
6	V6	RF 6-0	RF 6-0
7	V7	RF 7-0	RF 7-0
8	V8	-	RF 8-0
9	GND	-	-
10	Ind.1	Indicators	RF 1-0
11	Ind.2		RF 2-0
12	Ind.3		RF 3-0
13	Ind.4		RF 4-0
14	Ind.5		RF 5-0
15	Ind.6		RF 6-0
16	Ind.7		RF 7-0
17	Ind.8		-
18	Ind.com		-
19	VDC		-
20~26	N/A	-	-

Normally open TTL			
Actuator Terminals		RF Connector	
D-SUB 15/26Pin Male			
Pin No.	Define	SP7T	SP8T
1	TTL	RF 1-0	RF 1-0
2	TTL	RF 2-0	RF 2-0
3	TTL	RF 3-0	RF 3-0
4	TTL	RF 4-0	RF 4-0
5	TTL	RF 5-0	RF 5-0
6	TTL	RF 6-0	RF 6-0
7	TTL	RF 7-0	RF 7-0
8	TTL	-	RF 8-0
9	VDC	-	-
10	GND	-	-
11	Ind.1	Indicators	RF 1-0
12	Ind.2		RF 2-0
13	Ind.3		RF 3-0
14	Ind.4		RF 4-0
15	Ind.5		RF 5-0
16	Ind.6		RF 6-0
17	Ind.7		RF 7-0
18	Ind.8		-
19	Ind.com		-
20~26	N/A		-

◆ Product Selection

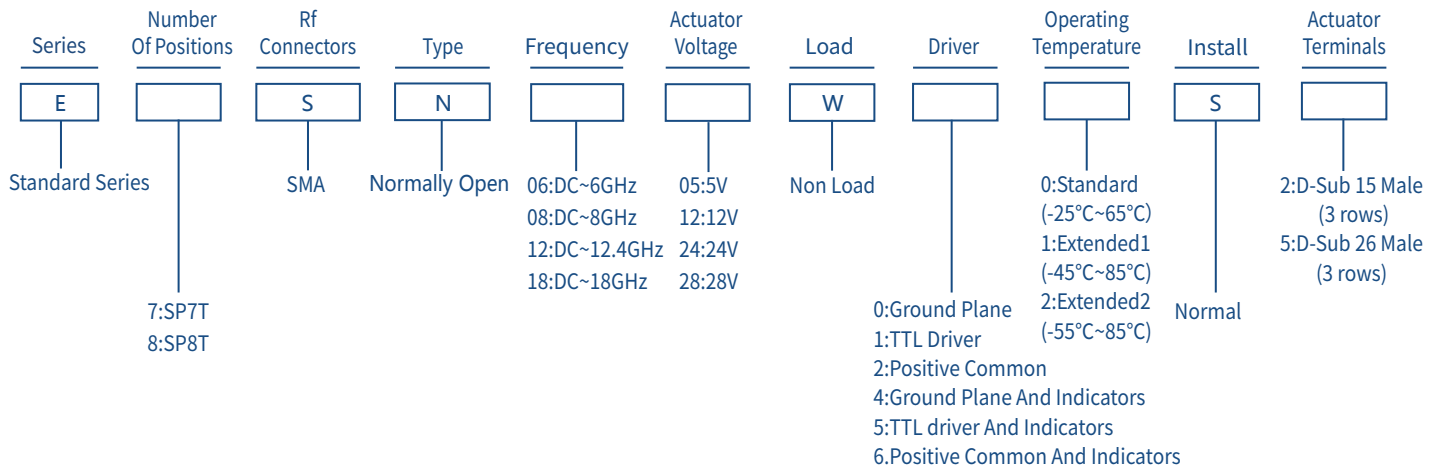

★ EXP: E7SN0605W00S2: Standard Series, SP7T, SMA, Normally Open, DC~6GHz, 5V, Non Load, Ground Plane, Standard, Normal, D-Sub 15 Male.